

**THE CHOICE OF CHAMPIONS**

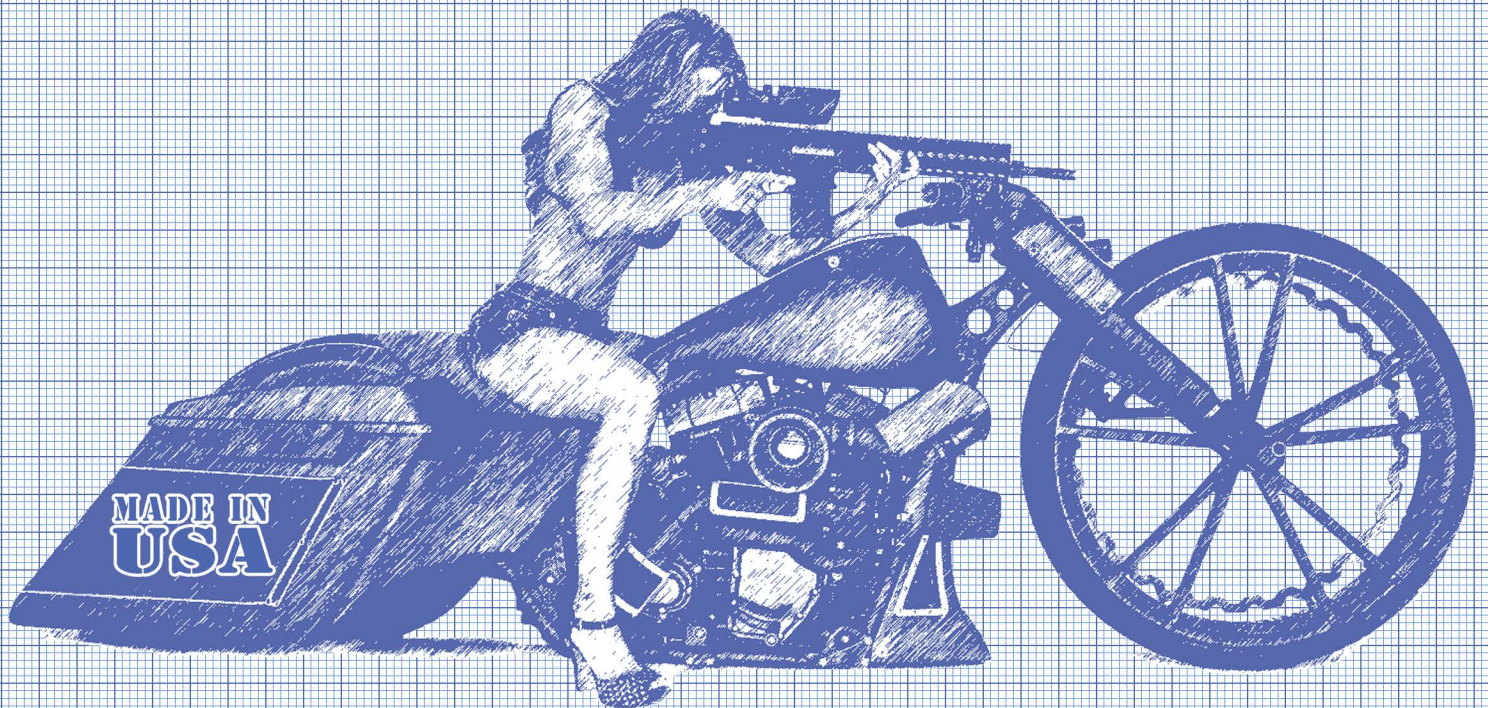

**SINCE 1997**



**WWW.AMERICANSUSPENSION.COM**

**321-285-9446**

**INFO@AMERICANSUSPENSION.COM**

# OUR PRODUCTS...

## BOLT ON NECK KIT



The American Suspension Bolt On Neck kit is a simple solution to the challenges of installing a 23", 26", 30", 32" wheel. Can easily be installed and removed. No cutting, no welding.

## SLIP FIT SHORT NECK

The American Suspension weld on Slip Fit Short Neck kit lets you put a 26" or 30" wheel on your bagger and keep the long low look. Fits HD Touring Models 1997-2017

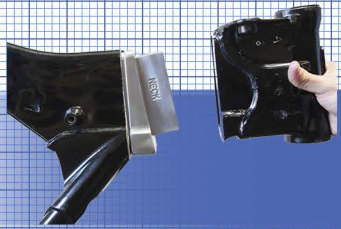

## EASY WELD ON WEDGE

The American Suspension Weld-on Wedge Rake kit will relocate your stock neck with the ease of a Slip Fit kit and fits a 26", 30", 32" front wheel.

## GRAND SLAM BUILDERS

The American Suspension Grand Slam Builders kit let's you put the neck anywhere you want on any bike, even an ultimate custom lay frame.

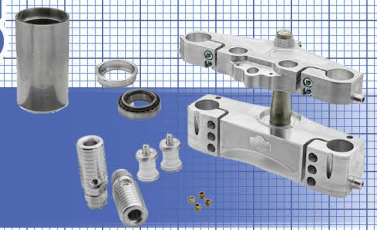

## 23" TRIPLE TREE

Allows you to upgrade your HD Touring bike to a 23" wheel without cutting your neck. A simple direct bolt on allows for easy installation and gives you perfect trail.

## MACH 8 INVERTED FORK

The Mach 8 Performance Touring Front End utilizes our patented perimeter valve technology and is for 21", 23", 26", 30", or 32" front wheel on your 1997-2017 Touring HD.

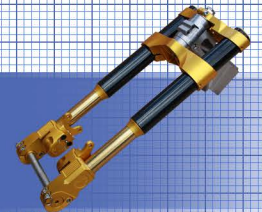

## DRAGON SPRINGER

The Dragon Slayer is the most sophisticated springer front end available for custom motorcycles. Get a modern performance and medieval style.

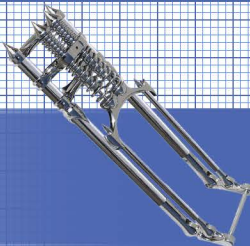

## B17 FRONT END

This complete fork includes fork legs, smooth top trees, axle, stem, brake caliper, hidden brake line, a hidden hardware kit, and multiple color options including chrome.





## F49 BAGGER LEGS

The F49 fork leg is machined from a single solid block of aircraft aluminum to bring your bike the smooth and modern look.

## STREET RACER SHOCKS

The American Suspension Street Racer Shock Absorbers comes with deflective disc race proven valving system that isolates bumps from the road and makes a great ride for lowered bikes,

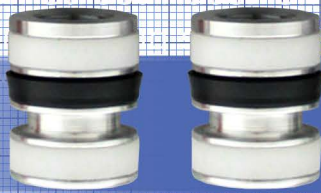

## FRONT AIR RIDE KIT

Turn your twin stock fork tubes into a custom air ride system. Simply add the pistons and the included cap that will accept your air line.

## FORK CANS

Machined from billet aluminum, our extended bagger fork cans helps you run a 26" or 30" front wheel on your HD Touring Bagger. Available in Chrome, Midnight Black and Black Mamba



## FAIRING MOUNT

All American Suspension Neck Kits are compatible with Road Glide Fairings. Convert any bike to a Road Glide with this Fairing Mount.

## FLTR BRACKET

Add stiffness and rigidity to your road glide fairing.



## RAKED HEADLIGHT BEZEL



Corrects head light angle on 30" rake kits.

## BRAKE LINE KIT

Custom brake line kits for all applications - even ABS models.



# THE EASE OF A THE RELIABILITY

Race Track Inspired  
Bearing Adjustment System.  
Set and Forget.

Fork Extensions completely  
fill the top tree to protect  
from high speed wobble.

Perfect trail for any 23", 26"  
30" or 32" conversions.

Multiple Redundant Fail Safe  
System designs provide the  
SAFEST Bolt On Neck.

Fully backed by a Limited Lifetime Warranty



# BOLT ON WITH EASY OF A WELD ON.

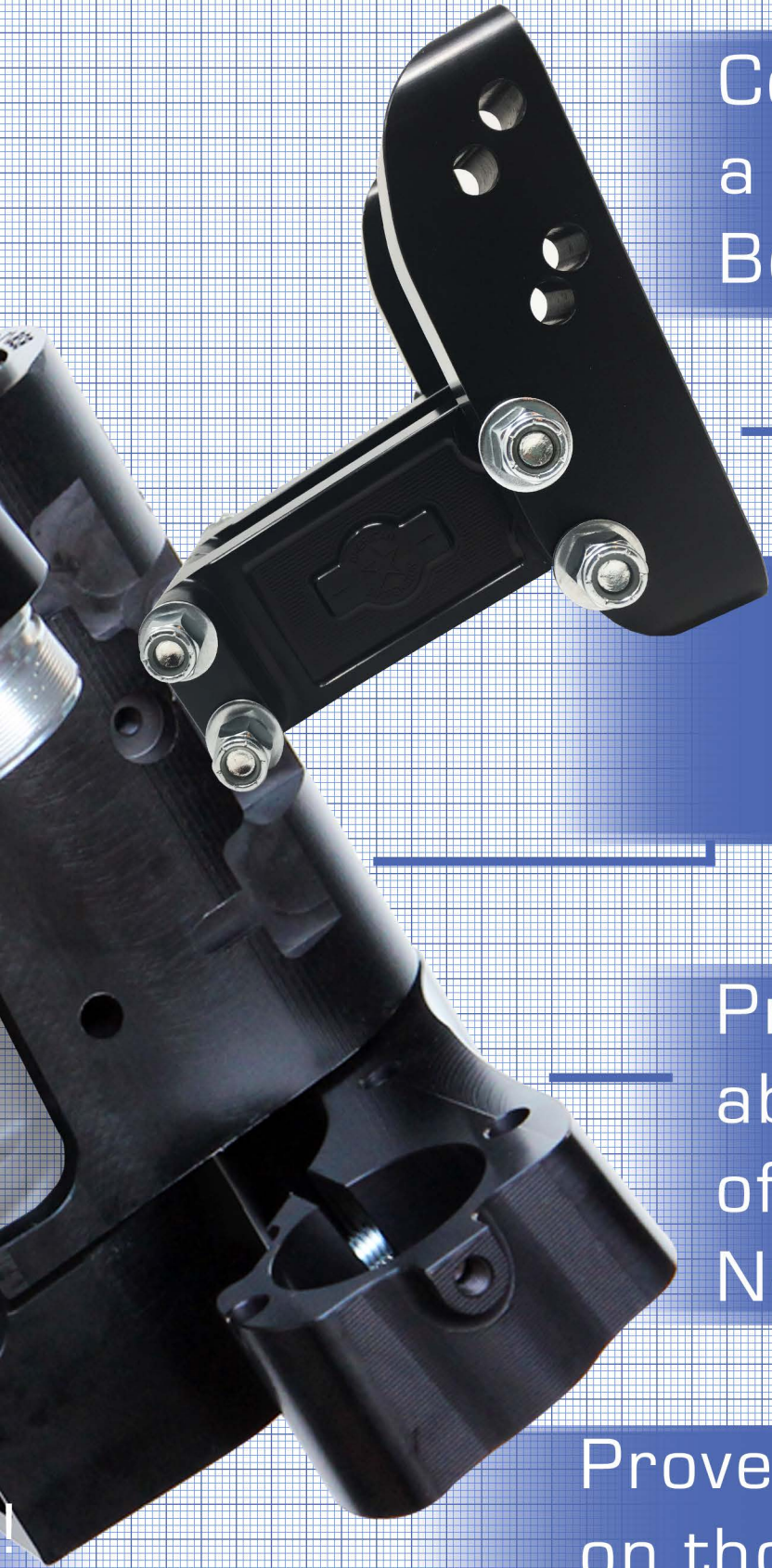

Convert any bike to a Road Glide with a Bolt On Fairing Mount.

The ONLY ONE-PIECE Bolt On available in the market.

Pressed in Stem gives absolute best handling of any available Bolt on Neck.

Proven by millions of miles, on thousands of bikes.

# MACH 8 INVERTED FORK

The Mach8 Performance Touring Front End utilizes our patented perimeter valve technology and fits a 21", 23", 26", 30" or 32" front wheel on your 1997 to 2017 Touring HD.

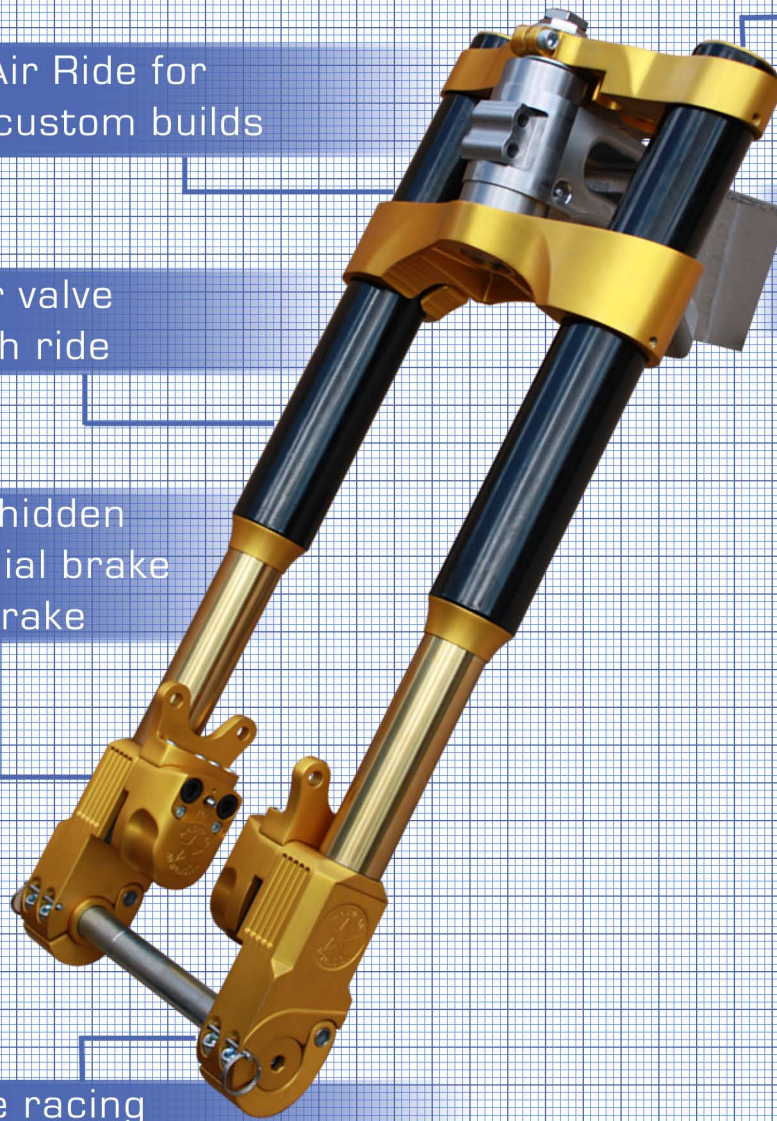

External Ride Adjusters

Optional Air Ride for layframe custom builds

Perimeter valve for smooth ride

Performance Triple Trees enhance stability

Choice of hidden brake, radial brake or stock brake



Endurance racing quick change style axle



# DRAGON SPRINGER

The D-66 Dragon Springer is the most sophisticated springer front end available for custom motorcycles. Get modern performance and a medieval style.

Trees for wide varieties of applications

Shock Absorbers controls wheel motion

Variable rate spring

Almost any length available

Multiple design options available

**D-69**

Sealed ball bearings at pivot points and billet rocker insures stability



# SLIP FIT SHORT NECK KIT

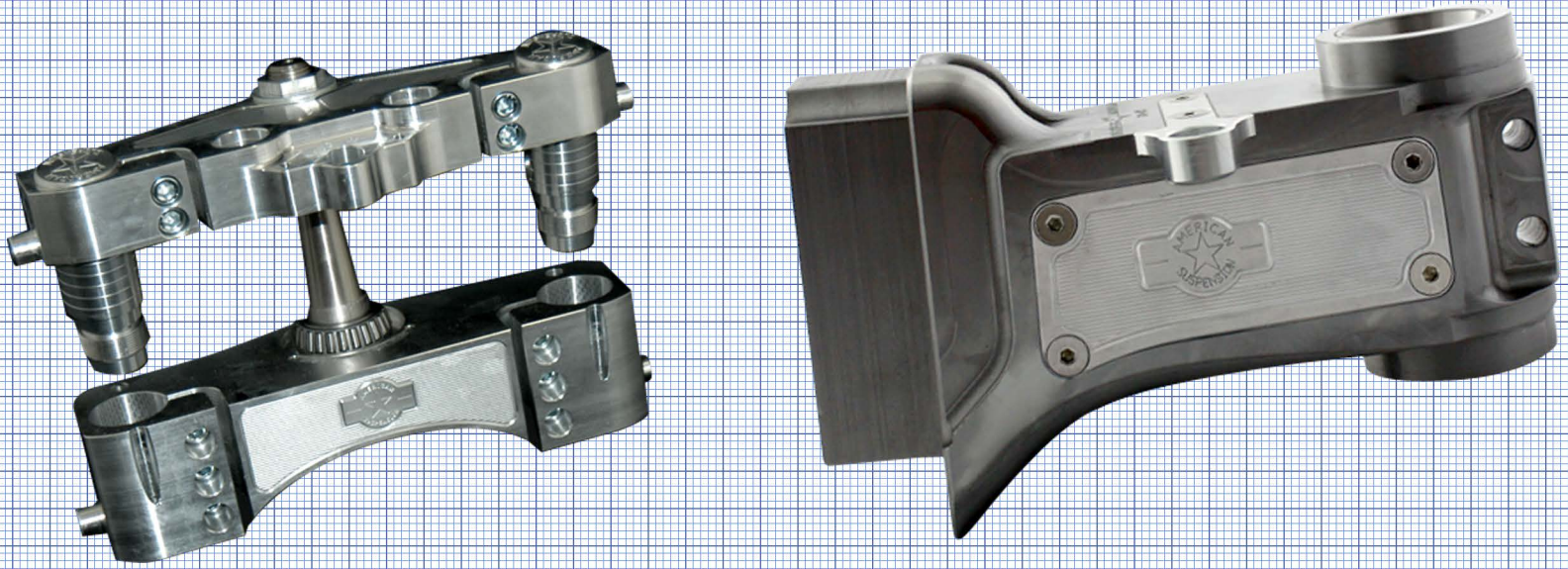

The American Suspension weld on Slip Fit Neck kit lets you put a 26", 30" or 32" wheel on your bagger and keep the long low look. Fits HD Touring Models 1997-2017

# EASY WELD ON WEDGE KIT

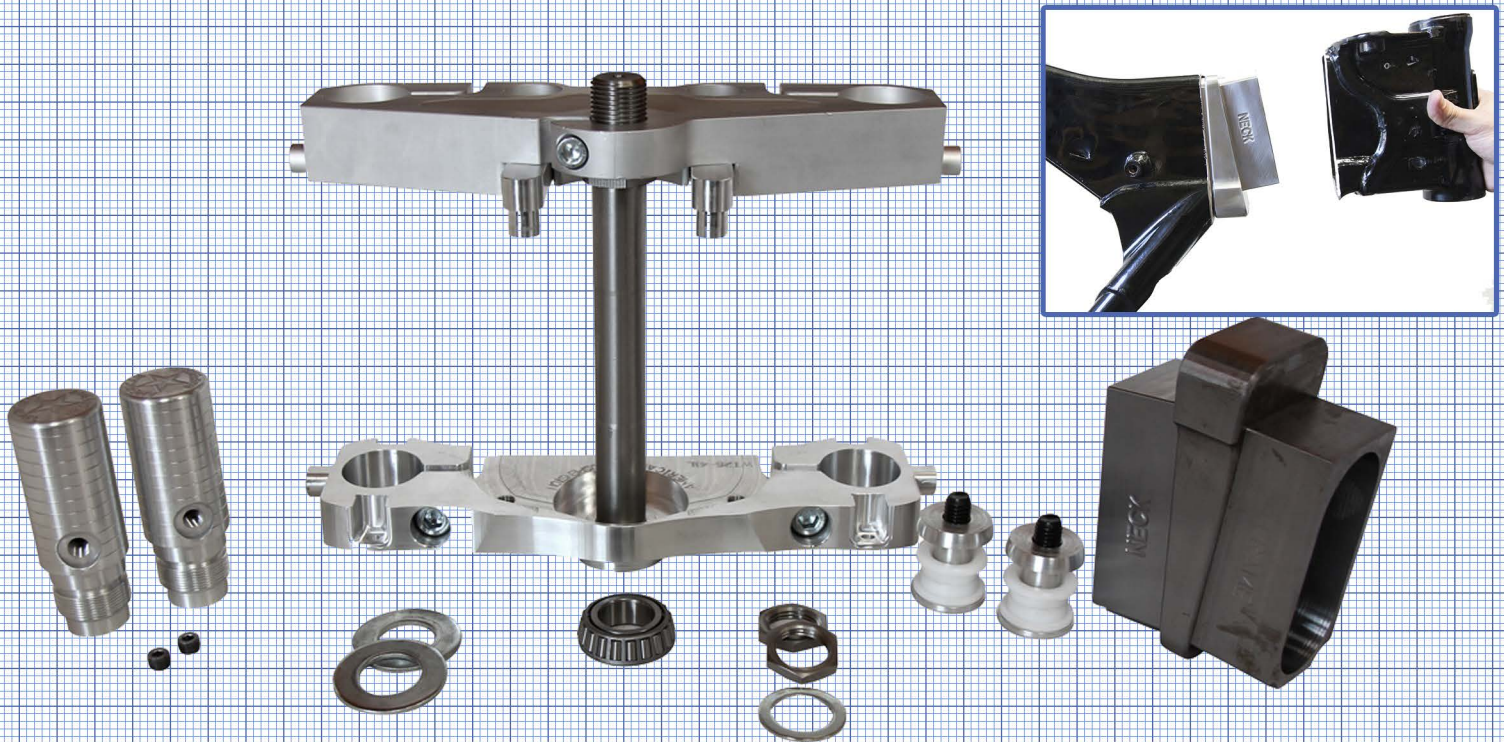

The American Suspension Weld-on Wedge Rake kit will relocate your stock neck with the ease of a Slip Fit kit and fits a 26" or 30" front wheel.



# GRAND SLAM BUILDERS KIT

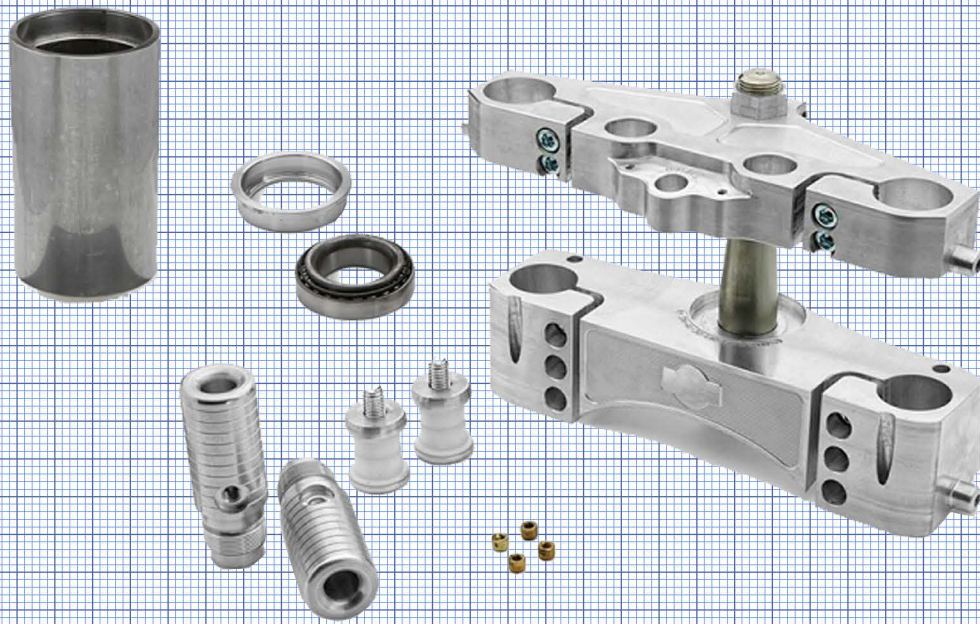

The American Suspension Grand Slam Builders Kit let's you put the neck anywhere you want on any bike, even an ultimate custom lay frame.

## 23" TRIPLE TREE KIT

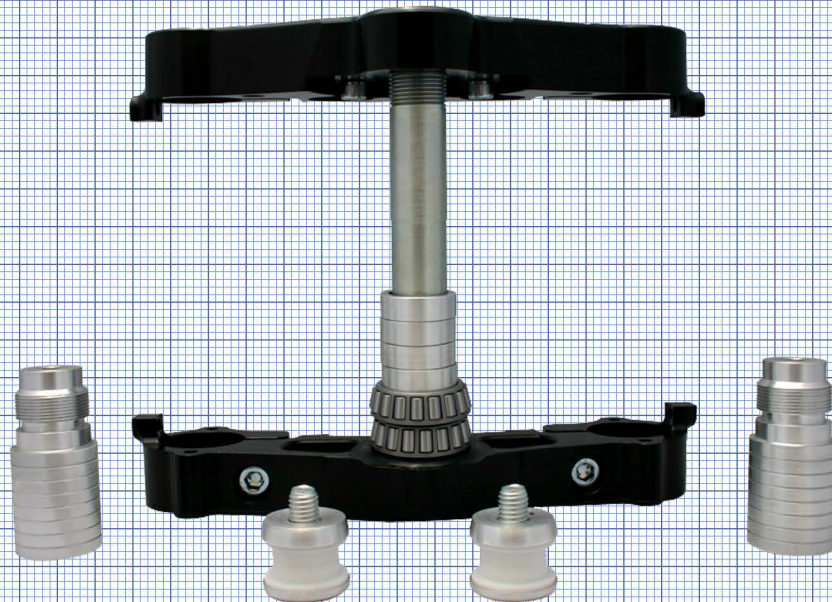

Allows you to upgrade your HD Touring bike to a 23" wheel without cutting your neck. A simple direct bolt on allows for easy installation and gives you perfect trail.

# THE CHOICE OF CHAMPIONS



Founder, Vince Costa, wins several motorcycle Road Racing Championships (Formula 1 750 Superspeed).

1985

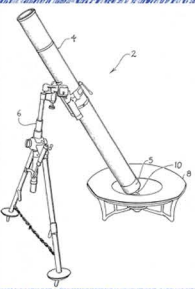

Shock Absorber for a lightweight gun system  
Patent 5,531,150

1995



The worlds first Inverted Fork Single Side Swingarm Chopper.

1998

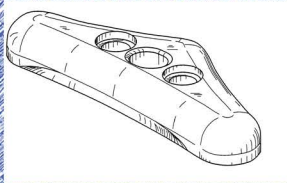

Smooth Top Triple Tree  
Patent: D544,818

2002

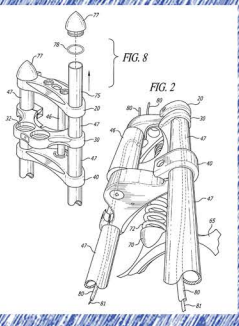

Dragon Springer Leading Axle Fork  
Patent: 7,441,622, D541,197, D542,718

2004

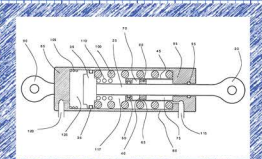

Through Shaft Shock Absorber for Soft Tails  
Patent: 7,017,893

2004

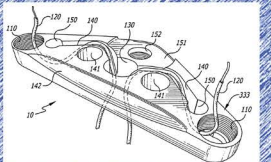

Hidden Line Triple Tree  
Patent: 7,357,403

2006



Created the first short neck Slip Fit weld on kit.

2011



Single Side Front Fork wins World Championship Builder.

2011



First VCU Steering Dampener Assembly

2015

The Street Racer Shock Absorber

2017

**1990**

Hydraulic Shock Absorber with pressure sensitive external valving.  
Patent: 4,936,424

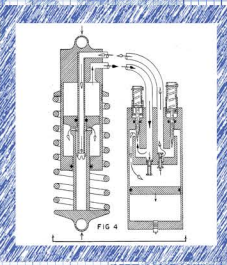

**1997**

American Suspension is formed. Used and sponsored by numerous racing teams.



Perimeter Valve Inverted Fork  
Patent: 6,520,524

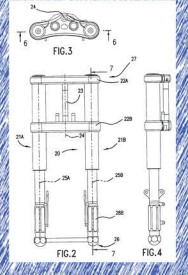

**2000**

The Air Raid Shock Absorber is created.



**2003**

Hidden Line / Integral Caliper Inverted Fork  
Patent: 7,318,502 & 7,565,955

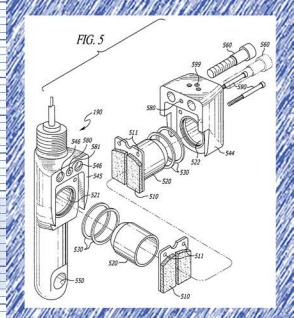

**2005**

Hidden Line Conventional Fork  
Patent: 7,497,307

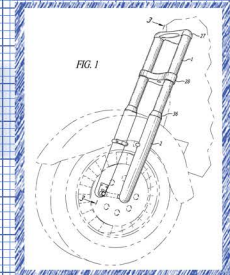

**2010**

Invented the Air Raid Fork Piston



**2014**

One-Piece Bolt on Neck  
Patent 9,079,631



**2016**

Created the Leading Axle Fork



**KILL YOUR COMPETITION**

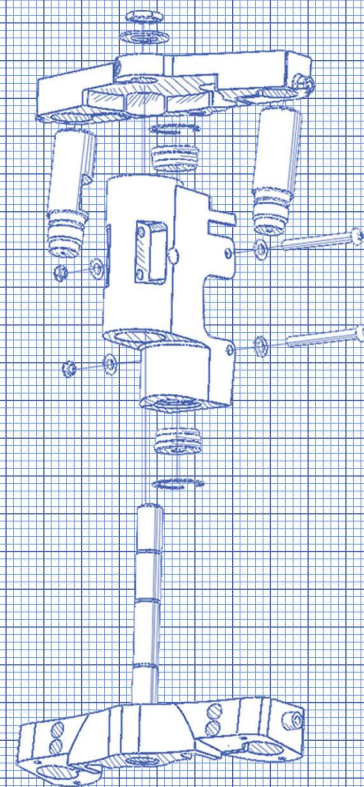
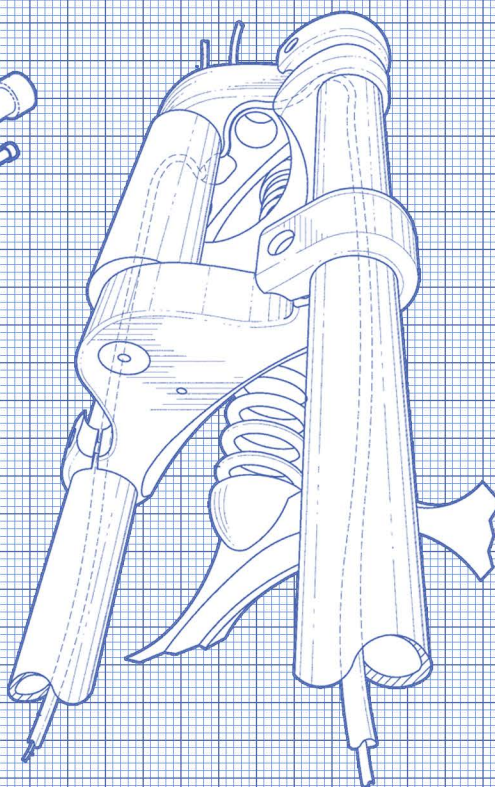
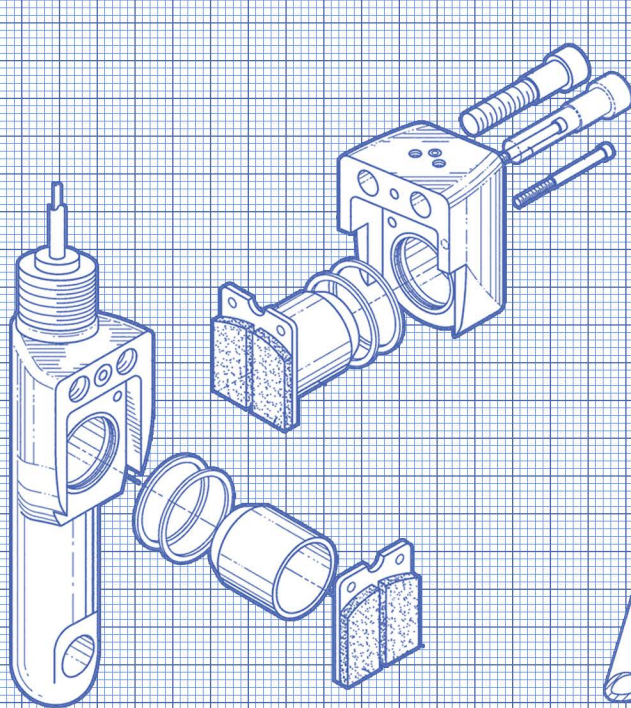
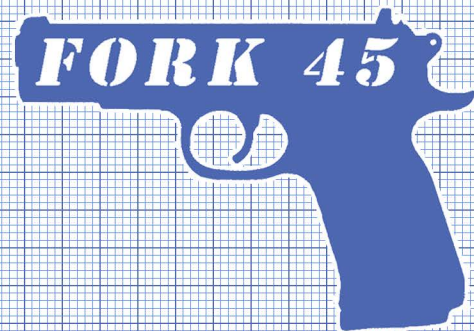
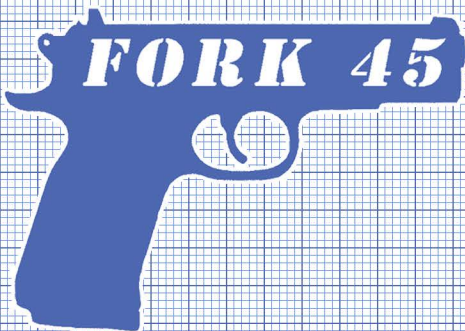

**PATENT US: 7318502 B2**

**PATENT:US 7441622 B2**

**PATENT:US 9079631 B1**



**BIKE BY MARK EVANS**

**WWW.AMERICANSUSPENSION.COM**

**321-285-9446**

**INFO@AMERICANSUSPENSION.COM**