

American Suspension

TK23 Installation Guide

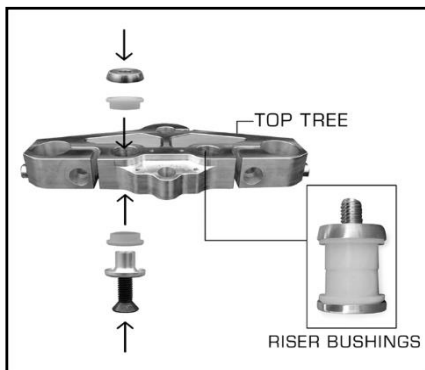

1 Install riser bushing sets into top tree. Insert steering stop screws on the bottom of top tree.

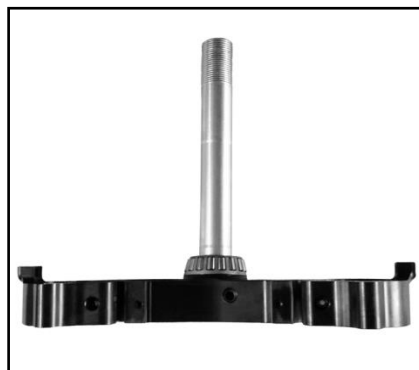

2 Pack supplied bearing with high quality grease. Install stem into lower tree then install greased bearing on stem.



3 For 2013 models and down re-use original upper bearing, while 2014 models and up, use provided bearing.



4 Insert lower tree and stem into steering neck. Screw stem into top tree.



5 Install fork cans on lower tree. Install both legs and torque lower tree bolts. Leave all top pinch bolts loose. Tighten stem while moving fork assembly until clicking disappears. Tighten 1/4 turn more. Trees should fall left & right with no drag. Lift legs up and down to check for any play in steering bearings.



6 Torque top tree pinch bolts. Then install stem pinch bolt on lower tree. Tighten all three pinch bolts to hold stem.



7 Check clearance between fender and lower tree. Install one or two top out spacers as needed in lower legs for fender clearance and use the provided limiters if needed, must use 2 per side on 2014 up.



8 Install wheel and fender. Tighten axle and all bolts. Loosen axle and all bolts & fasteners except top tree bolts. Bounce the bike a few times. Now tighten all bolts & fasteners to correct torque and check for play in steering. Install brake line to fit your needs. Reinstall removed parts to H-D specifications.

*****American Suspension or our Dealers are not responsible for fender clearance issues, you must inspect prior to riding bike*****